

NORTH SIDE

TYPICAL CROSS-SECTION - STATIONS 509+27.25 TO 513+98.17  
(LOOKING UPSTATION)

SOUTH SIDE

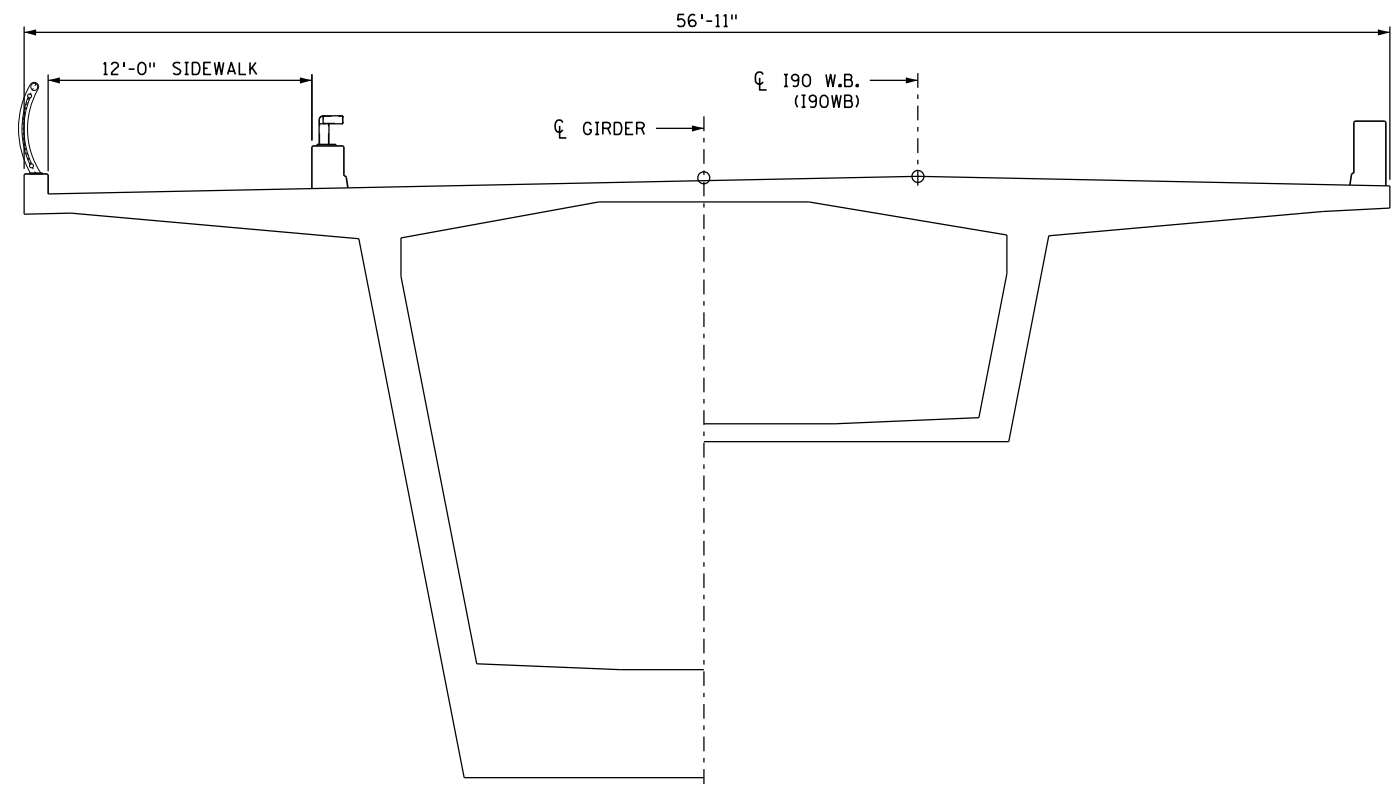
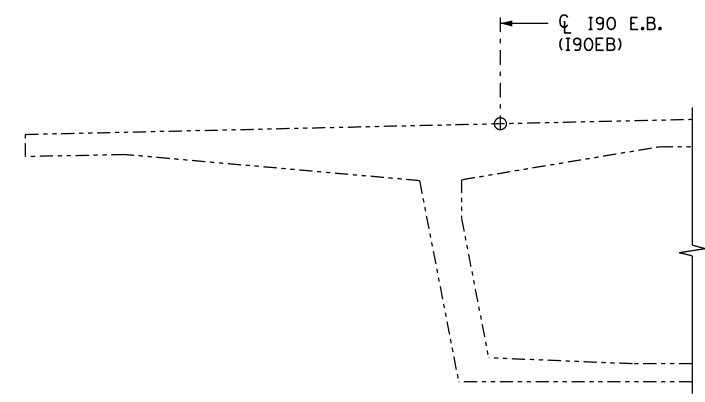

NORTH SIDE

TYPICAL CROSS-SECTION - STATIONS 513+98.17 TO 526+70.92  
(LOOKING UPSTATION)

SOUTH SIDE

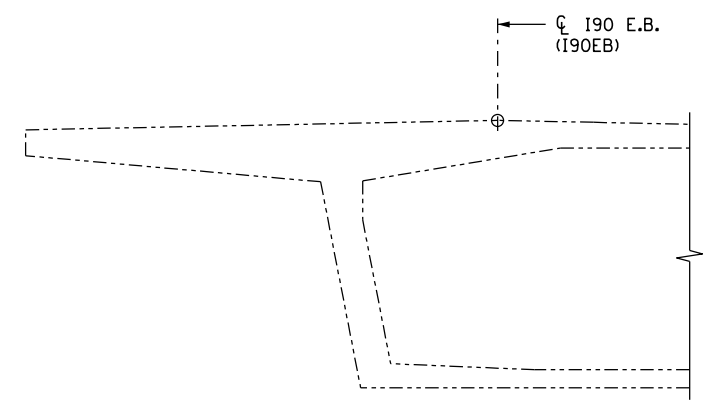

MAXIMUM DEPTH SECTION      MINIMUM DEPTH SECTION

9/27/2011 2:12:34 PM G:\Projects\Drawings\Struct\PED-Bridge-Options\Options\Option\_1.dgn

	CERTIFIED BY _____	<table border="1"> <thead> <tr> <th>DRAWING REVISION</th> <th>NO.</th> <th>BY</th> <th>DATE</th> <th>DESCRIPTION</th> </tr> </thead> <tbody> <tr> <td> </td> <td> </td> <td> </td> <td> </td> <td> </td> </tr> <tr> <td> </td> <td> </td> <td> </td> <td> </td> <td> </td> </tr> <tr> <td> </td> <td> </td> <td> </td> <td> </td> <td> </td> </tr> </tbody> </table>	DRAWING REVISION	NO.	BY	DATE	DESCRIPTION																TITLE: WEST BOUND BRIDGE WIDENING OPTION SECTION 1	DES: ---	DR: ---	APPROVED: _____	BRIDGE NO. ---
	DRAWING REVISION		NO.	BY	DATE	DESCRIPTION																					
LICENSED PROFESSIONAL ENGINEER      DATE NAME: CHRISTOPHER J. BURGESS      LIC. NO. 45833	SHEET NO.      OF      SHEETS																										

9/27/2011 2:13:06 PM G:\Projects\Drawings\Struct\PED-Bridge-Options\Options\_1.dgn

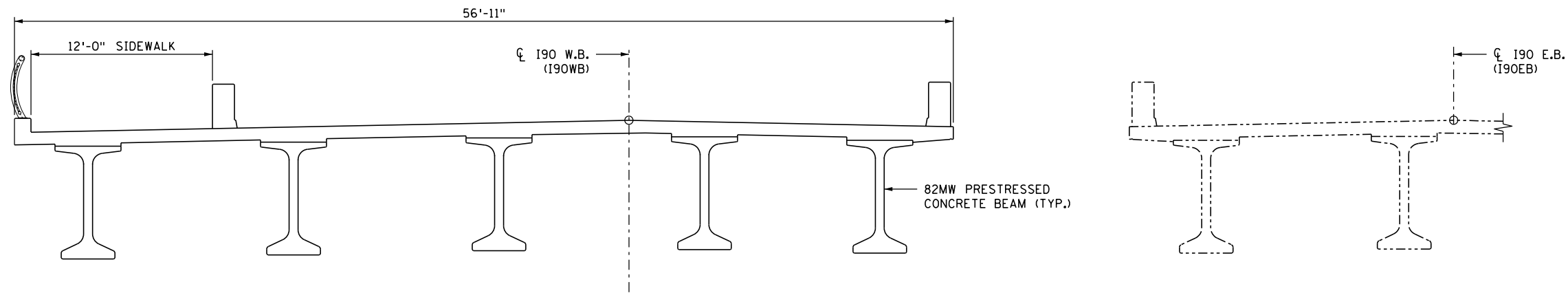

NORTH SIDE

TYPICAL CROSS-SECTION - STATIONS 526+70.92 TO 535+97.00  
(LOOKING UPSTATION)

SOUTH SIDE

	CERTIFIED BY _____		DATE _____		TITLE: WEST BOUND BRIDGE WIDENING OPTION SECTION 2	DES: ---	DR: ---	APPROVED: _____	BRIDGE NO. ---
	LICENSED PROFESSIONAL ENGINEER NAME: CHRISTOPHER J. BURGESS		LIC. NO. 45833			CHK: ---	CHK: ---		

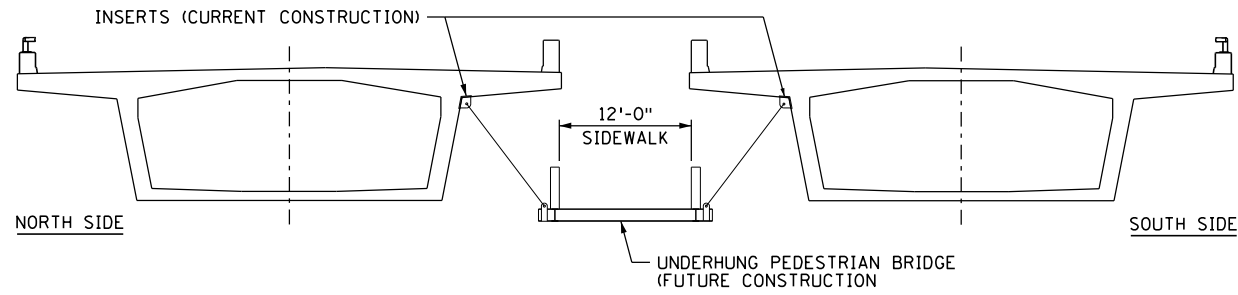

UNIT 1

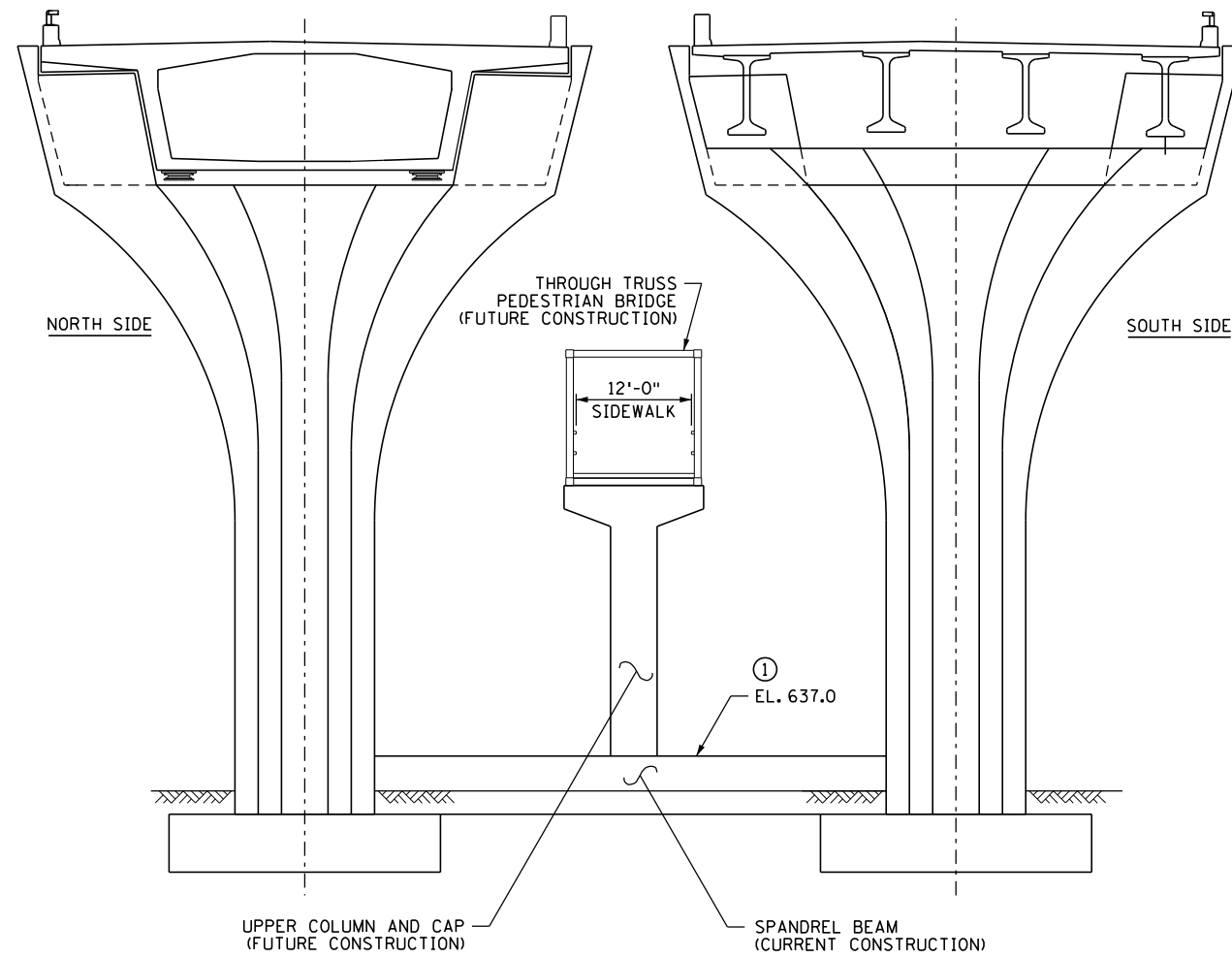

PIER 4

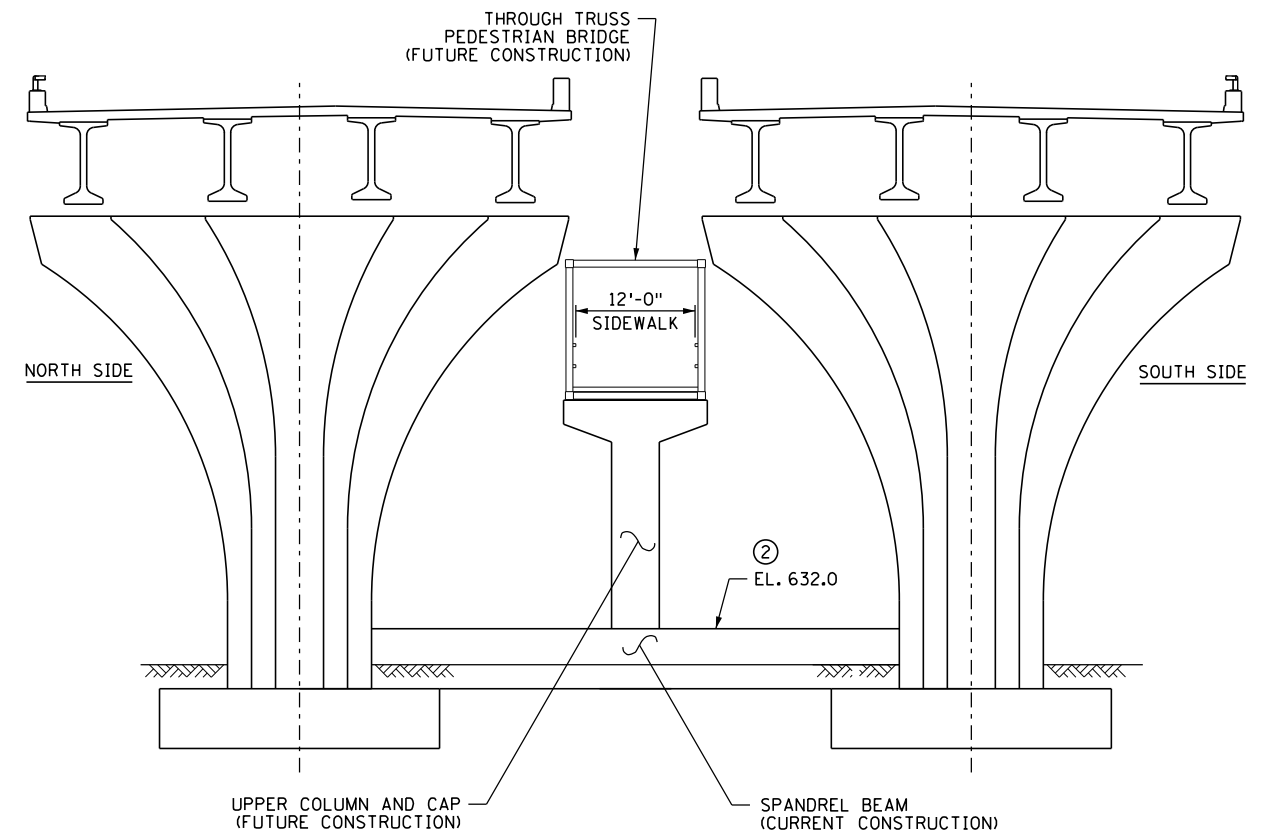

PIER 9

NOTES:

- ALTERNATIVELY, JOIN THE FOOTINGS AND ELIMINATE SPANDREL BEAMS.
- ① SPANDREL BEAM AT PIER 4 EXPOSED ABOVE WATER ~ 95% OF THE TIME.
- ② SPANDREL BEAM AT PIER 9 EXPOSED ABOVE WATER ~ 50% OF THE TIME

9/27/2011 2:11:27 PM G:\Projects\Presboch\Struct\PED-Bridge\_Options\Option\_6.dgn

	CERTIFIED BY _____	DATE _____	NO. BY DATE DESCRIPTION _____ _____ _____	TITLE: SUSPENDED STRUCTURE OPTION	DES: ---	DR: ---	APPROVED: _____	BRIDGE NO. ---
	LICENSED PROFESSIONAL ENGINEER NAME: CHRISTOPHER J. BURGESS LIC. NO. 45833				CHK: ---	CHK: ---		